



EXPERIENCE INHERITANCE
TECHNOLOGICAL INNOVATION



VMC/PM Series

Vertical machineing center series

LIGHT GIANT PRECISION INDUSTRY CO.,LTD.
No.38, Lane 276, Guangfu Rd., Shengang Dist.,
Taichung City, Taiwan 429, R.O.C.
TEL: +886-4-25611583
FAX: +886-4-25611530

LIGHT GIANT PRECISION INDUSTRY (HUAI AN) CO.,LTD.
No.188 Guangzhou Road, Huai'an District, Huai'an City,
Jiangsu Province, China
TEL: +86-517-89721666
FAX: +86-517-89721668
E-mail: grs_hk@hotmail.com
https:// : www.lg-cnc.com

AGENT





Product catalog

Company Product

T-series 02

High speed drilling and milling
machining center machine

VMC series 04

Three axis rail processing machine

PM-L series 07

High precision machining center machine

PM-LH series 13

Two lines and one hard machining center machine

Standard optional specifications 18

Standard selection



LIGHT GIANT PRECISION INDUSTRY CO., LTD., ESTABLISHED SINCE THE CONTINUOUS EFFORTS IN CNC LATHE, VERTICAL MACHINING CENTER, HORIZONTAL MACHINING CENTER AND LONGMEN MACHINING CENTER AND OTHER PARTS OF THE IMPROVEMENT, COMMITTED TO THE DEVELOPMENT OF NEW PRODUCTS, IN ORDER TO LOOK FORWARD TO A NEW CAREER PEAK.

WE PROVIDE MULTIFUNCTIONAL AUTOMATIC PROCESSING EQUIPMENT WITH HIGH PRECISION, HIGH EFFICIENCY AND HIGH STABILITY. ACCORDING TO CUSTOMER BUDGET AND PRODUCTION CONDITIONS, DESIGN AND PLANNING ON BEHALF OF CUSTOMERS, FOR CUSTOMERS TO REDUCE THE COST OF MACHINE ACQUISITION AND OPERATION MANAGEMENT AND MARKETING, AND IMPROVE PRODUCTION EFFICIENCY TO CREATE MAXIMUM PROFITS.

PERFECT MANAGEMENT TEAM, INCLUDING MARKETING, RESEARCH AND DEVELOPMENT, PROCUREMENT, PRODUCTION, SALES SERVICE, CAN PROVIDE CUSTOMERS WITH STRONG AND POWERFUL SUPPORT AT ANY TIME. IN ADDITION TO IMPROVING CUSTOMER SATISFACTION AS THE BIGGEST PURPOSE, WE CONTINUE TO DEVELOP AND DESIGN GREEN PROCESSING MACHINES FROM THE PERSPECTIVE OF CARING FOR THE ENVIRONMENT, TO BUILD A GOOD INTERACTIVE RELATIONSHIP BETWEEN USERS AND THE ENVIRONMENT.

PHOTOGIANT'S PRODUCTS CAN ACHIEVE PRODUCTION AUTOMATION, STANDARDIZATION, MAXIMIZATION OF PRODUCTIVITY AND MINIMIZATION OF COSTS. IS THE MOST POWERFUL BACKING FOR YOUR CAREER DEVELOPMENT.

BUSINESS PHILOSOPHY: QUALITY FIRST, SERVICE FIRST;

INTEGRITY IS THE SUSTAINABLE BASE OF THE ENTERPRISE, THE CUSTOMER IS THE SOURCE OF ENTERPRISE VITALITY;

CREATE VALUE FOR CUSTOMERS, CREATE OPPORTUNITIES FOR EMPLOYEES, CREATE BENEFITS FOR THE SOCIETY!

ENTERPRISE SPIRIT: RESPONSIBILITY IS THE GUARANTEE OF ENTERPRISE TRUST, IMPROVEMENT IS THE UPWARD FORCE OF ENTERPRISE;

POSITIVE IS THE ENTERPRISE TO WIN THE POWER, INNOVATION IS THE ENTERPRISE COMPETITION WEAPON!

T-600

Drilling and milling machine

High rigid body segment

- ※ HT300 cast iron material, low melting point(1145~1250°C), Small shrinkage during solidification, compressive strength and hardness close to carbon steel, Good shock absorption, permanent guarantee quality.
- ※ Tempering treatment: eliminate the internal stress, castings keep stable for along time, no deformation
- ※ Body design: Adopt integrated for ming technology, box structure. internal W Reinforcing bars and rice reinforcement design, so that the rigidity of the bed is greatly improved
- More stable processing, while extending the service life of machine tools.



Spindle motor characteristic curve

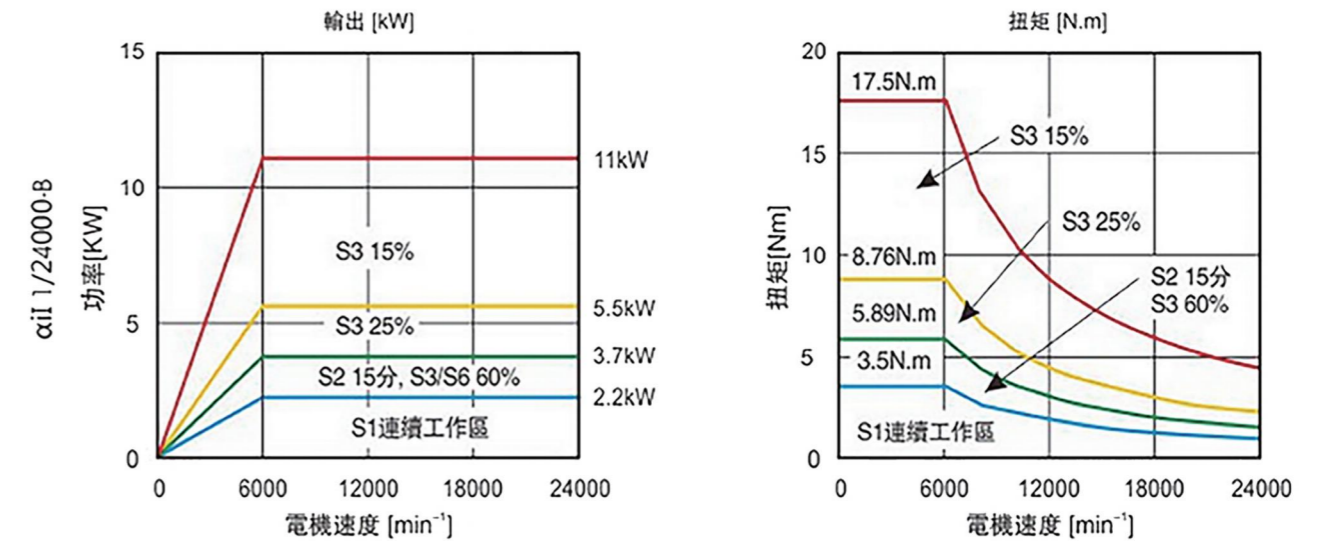

machinability

cutter: D12 end mill
 Knife length: 35mm
 material: 6061aluminum
 Maximum continuous processing capacity
 Depth of cut: 20mm
 Cutting width: 3mm
 Spindle speed: 6000rpm
 feed: 2000mm/min

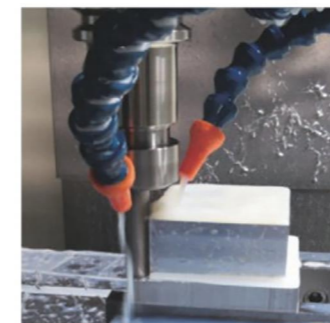

Tapping test

material: 45#

 Maximum tapping size tap: M8*1.25
 Spindle speed: 250rpm
 feed: 440mm/min
 Spindle load: 75%



MODEL		UNIT	T-600
Travel	X axis travel	mm	600
	Y axis travel	mm	400
	Z axis travel	mm	300
	Distance from spindle center to column	mm	410
	Distance from spindle nose to table	mm	150 ~ 450
Table	Table area	mm	700 × 360
	Max.load of table	kg	300
	T-slot	mm	3-14 × 100
Spindle	Spindle taper		BT30
	Spindle speed	rpm	24000
	Spindle drive		Direct connection
	Spindle motor	kw	ai11/24000
	Spindle cooling		Oil cooler
Feed Drive	Rapid movement on (X、 Y axis)	m/min	48
	Rapid movement on (Z axis)	m/min	48
	3 Axis slide		Three-axis roller guide
	Cutting feed rate	m/min	5-20000
	Minimum feed unit	mm	0.001
	3 Axis motor output (X、 Y、 Z)	kw	ais8/4000 、 ais12B/4000
A.T.C	Magazine type		Umbrella knife library
	Tool capacity	Pcs	21
	Max.tool diameter	mm	60/80
	Max.tool length	mm	250
	Max.tool weight	kg	3
Precision	Positioning	mm	0.007
	Repeatability	mm	0.006
Other	Power requirement	KVA	15
	Floor space(L × W × H)	mm	1900 × 2300 × 2500
	Air source requirements	kg	7
	Machine net weight	kg	About 2900
	Controller		FANUC Oi-TF

VMC-855

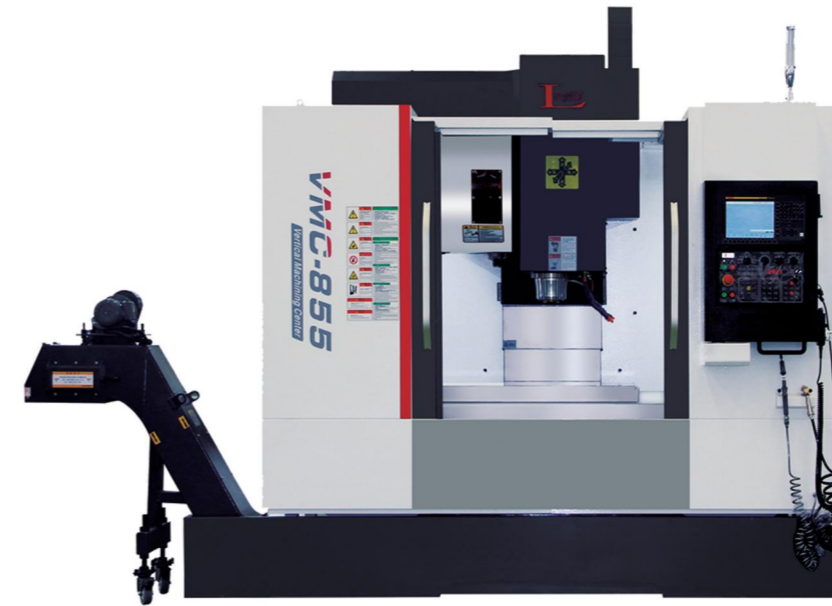

VMC-855

X axis 800
Y axis 550
Z axis 550

*The only way for competitive edge
is to pursue efficiency and quality*

VMC-1100

X axis 1100
Y axis 600
Z axis 600

VMC-1100



Each machine has been inspected before shipping to ensure optimal operation performance through Laser Calibration and Ball bar Circularity Inspection



ISO 10791-7 Test PIECE

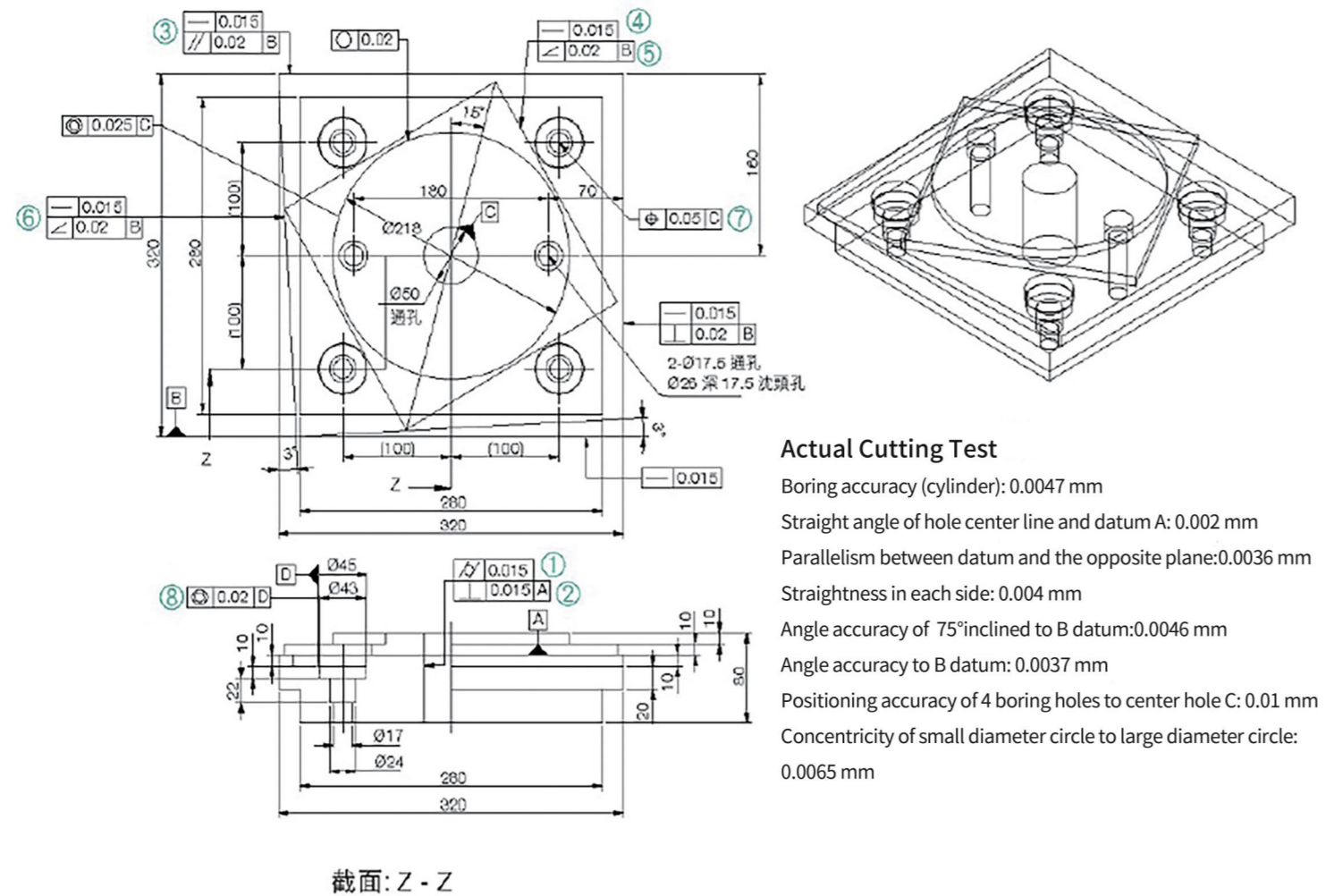

	MODEL	UNIT	VMC-855	VMC-1100
Travel	X axis travel	mm	800	1100
	Y axis travel	mm	550	600
	Z axis travel	mm	550	600
	Distance from spindle center to column	mm	610	650
	Distance from spindle nose to table	mm	140 ~ 690	120 ~ 720
Table	Table area	mm	1000 × 550	1200 × 600
	Max.load of table	kg	500	800
	T-slot	mm	18-5 × 90	18-5 × 100
Spindle	Spindle taper		BT40	BT40
	Spindle speed	rpm	10000	10000
	Spindle drive		Belt type	Belt type
	Spindle motor	kw	11/15	11/15
	Spindle cooling		lubricating grease	lubricating grease
Feed Drive	3Axis motor output (X、Y、Z)	kw	3/3/3	3/3/3
	Rapid traverse (X、Y axis)	m/min	48	36/30
	Triaxial track specifications	mm	X axis: 35 Y axis: 45 Z axis: 45	X axis: 45 Y axis: 45 Z axis: 45
	Minimum feed unit	mm	0.001	0.001
	A.T.C	Magazine type		Knife arm type
Tool magazine capacity		Pcs	24	24
Full knife diameter		mm	Ø 80	Ø 80
The diameter of the hollow blade		mm	Ø 150	Ø 150
Longest tool		mm	250	250
Precision	Positioning	mm	0.007	0.007
	Repeatability	mm	0.006	0.006
Other	Power requirement	KVA	25	25
	Floor space(L × W × H)	mm	2600 × 2300 × 2750	3100 × 2470 × 2800
	Air source requirements	kg	6.5	6.5
	Machine weight	kg	About 5350	About 6350
	Controller		FANUC Oi-TF	FANUC Oi-TF

PM-L850/900/1100



PM-L850

X axis 800
Y axis 500
Z axis 500

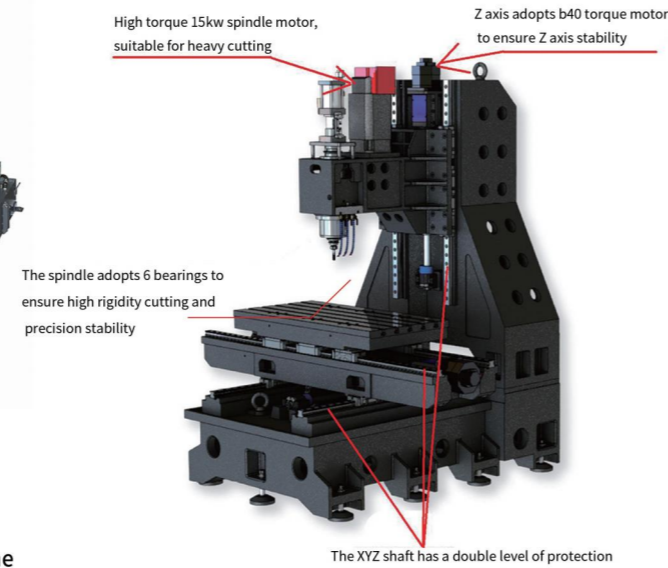

New upgraded version

Class A performance, leading excellence

Z-axis acceleration up to 0.75G can shorten the tool change time

The rapid feed of the three - axis upgrade reduces the non - milling time

Optional 12000rpm oil-gas lubricated direct spindle can ensure surface grain processing

High rigidity column enhances milling and industrial efficiency

PM-L1100

X axis 1100
Y axis 650
Z axis 650



High mirror finish



MODEL		UNIT	PM-L850	PM-L900	PM-L1100
Travel	X axis travel	mm	800	900	1100
	Y axis travel	mm	500	650	650
	Z axis travel	mm	500	650	650
	Distance from spindle nose to table surface	mm	120 ~ 620	120 ~ 770	120 ~ 770
Table	Table area	mm	1000 × 500	1000 × 600	1200 × 600
	Max.load of table	kg	600	700	800
	T-slot	mm	18-5 × 100	18-5 × 125	18-5 × 125
Spindle	Spindle taper		BT40/150		
	Spindle speed	rpm	10000		
	Spindle drive		Belt type		
	Spindle motor	kw	11/15		
	Spindle cooling		lubricating grease		
Feed Drive	Rapid movement on (X、 Y axis)	m/min	48	48	48
	Rapid movement on (Z axis)	m/min	48	36	36
	3Axis slide		Three axis roller	Three axis roller	Three axis roller
	X axis rail specifications	mm	35	35	45
	Y axis rail specifications	mm	45	45	45
	Z axis rail specifications	mm	45	45	45
	Cutting feed rate	mm/min	1-10000	1-10000	1-10000
	Minimum feed unit	mm	0.001	0.001	0.001
	3Axis motor output (X、 Y、 Z)	kw	3	3	3
	A.T.C	Magazine type		Knife arm type	
Tool magazine capacity		PCS	24		
Max.tool diameter		mm	Ø 80/ Ø 150		
Max.tool length		mm	300		
Max.tool weight		kg	7kg		
Precision	Positioning	mm	0.007		
	Repeatability	mm	0.006		
Other	Power requirement	KVA	25	25	25
	Floor space(L × W × H)	mm	2650x2200x2600	2700x2350x2800	3100x2470x2800
	Air source requirements	kg	7		
	Machine weight	kg	About 6450	About 5550	About 6950
	Controller		FANUC Oi-TF		

PM-L1200/1300

Three axis processing machine

PM-L1200

X axis 1200
Y axis 700
Z axis 700

PM-L1300

X axis 1300
Y axis 800
Z axis 700



Optimal Structure Design

High Rigidity Lifetime Stability!

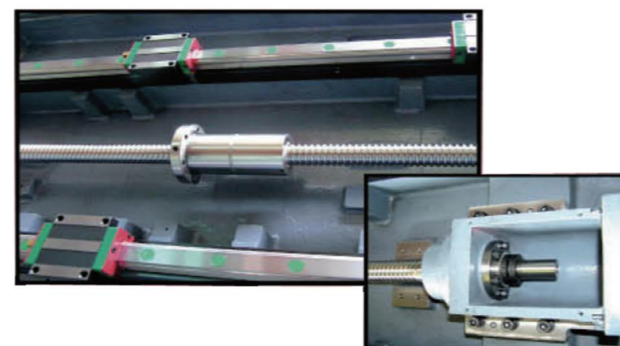

PRECISION BALL SCREW

Three axes are transmitted by high precision ball screws ,preloaded,hardened and ground-assuring dependable feed accuracy.

MODEL		UNIT	PM-L1200	PM-L1300
Travel	X axis travel	mm	1200	1300
	Y axis travel	mm	700	800
	Z axis travel	mm	700	700
	Distance from spindle center to column	mm	120-820	120-820
	Distance from spindle nose to table	mm	762	762
Table	Table area	mm	1400 × 700	1500 × 700
	Max.load of table	kg	900	1000
	T-slot	mm	22-5 × 125	18-5 × 125
Spindle	Spindle taper		BT50/OPT:BT40	BT50/OPT:BT40
	Spindle speed	rpm	6000	6000
	Spindle drive		Belt type	Belt type
	Spindle motor	kw	15/18.5	15/18.5
	Spindle cooling		lubricating grease	lubricating grease
Feed Drive	3Axis motor output (X、 Y、 Z)	kw	B40/2000	B40/2000
	Three-axis rapid displacement	m/min	24/24/20	24/24/20
	Triaxial track specifications	mm	X axis:45 Y axis:45 Z axis:45	X axis:45 Y axis:45 Z axis:45
	Minimum feed unit	mm	0.001	0.001
A.T.C	Magazine type		Knife arm type	Knife arm type
	Tool magazine capacity	Pcs	24	24
	Full knife diameter	mm	Ø 110	Ø 110
	The diameter of the hollow blade	mm	Ø 200	Ø 200
Precision	Positioning	mm	0.007	0.007
	Repeatability	mm	0.006	0.006
Other	Power requirement	KVA	30	30
	Floor space(L × W × H)	mm	3000 × 2500 × 2800	3400 × 2930 × 2800
	Air source requirements	kg	6.5	6.5
	Machine weight	kg	About 7500	About 8500
	Controller		FANUC 0i-TF	FANUC 0i-TF

PM-L1500/1600/1800

Three axis processing machine

PM-L1600

X axis 1600

Y axis 800

Z axis 700

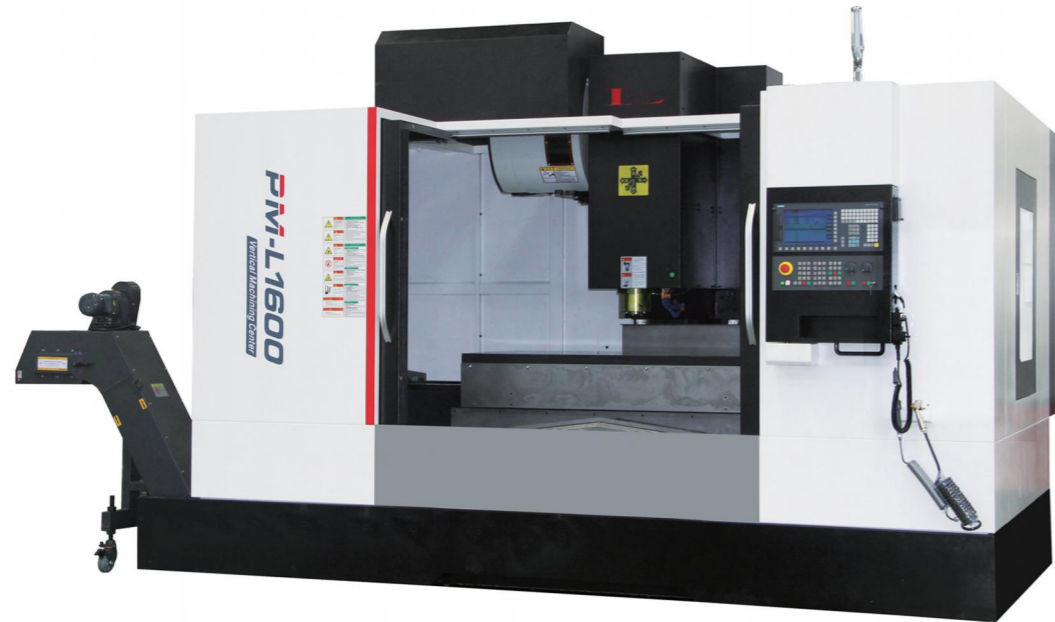

Triaxial fast feed rate 24/24/20 m/min

Worktable load 1500kg

The spindle adopts belt drive mode

6000rpm with rigid tapping function

Optional gear box structure

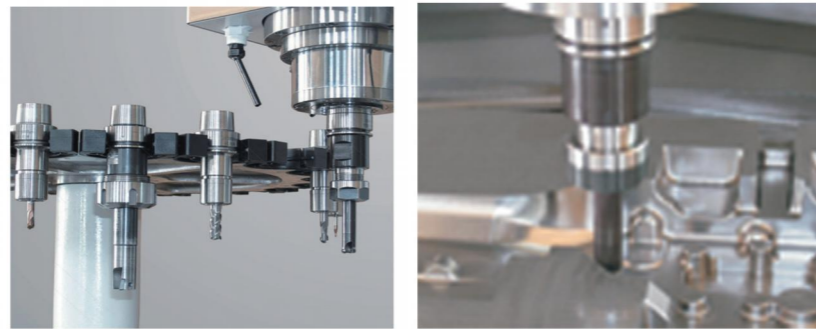
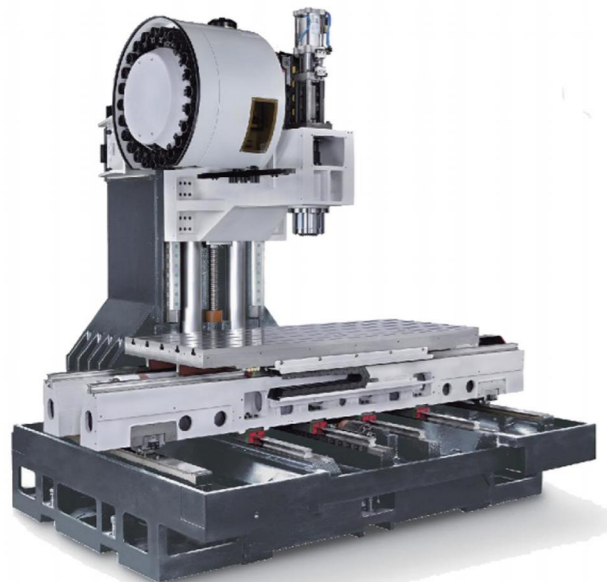

MODEL		UNIT	PM-L1500	PM-L1600	PM-L1800
Travel	X axis travel	mm	1500	1600	1800
	Y axis travel	mm	800	800	900
	Z axis travel	mm	700	700	700
	Distance from spindle center to column	mm	951	951	1080
	Distance from spindle nose to table	mm	180-880	180-880	180-880
Table	Table area	mm	1700 × 800	2000 × 900	2000 × 900
	Max.load of table	kg	1500	1900	1900
	T-slot	mm	22-5 × 150	22-5 × 150	22-5 × 165
Spindle	Spindle taper		BT50	BT50	BT50-190
	Spindle speed	rpm	6000	6000	6000
	Spindle drive		Belt type	Belt type	Belt type
	Spindle motor	kw	15/18.5	15/18.5	18.5/22
	Spindle cooling		lubricating grease	lubricating grease	lubricating grease
Feed Drive	3Axis motor output (X、Y、Z)	kw	B40/2000	B40/2000	B40/2000
	Three-axis rapid displacement	m/min	24/24/20	24/24/20	24/24/20
	Triaxial track specifications	mm	X axis:55 Y axis:45 Z axis:55	X axis:55 Y axis:45 Z axis:55	X axis:55 Y axis:45 Z axis:55
	Minimum feed unit	mm	0.001	0.001	0.001
	A.T.C	Magazine type		Knife arm type	Knife arm type
Tool magazine capacity		Pcs	24	24	24
Full knife diameter		mm	Ø 110	Ø 110	Ø 110
The diameter of the hollow blade		mm	Ø 200	Ø 200	Ø 200
Longest tool		mm	300	300	300
Precision	Positioning	mm	0.007	0.007	0.007
	Repeatability	mm	0.006	0.006	0.006
Other	Power requirement	KVA	30	30	30
	Floor space(L × W × H)	mm	3900 × 3280 × 3150	3900 × 3280 × 3150	4100 × 3280 × 3150
	Machine weight	kg	About 11500	About 12300	About 13800
	Controller		FANUC 0i-TF	FANUC 0i-TF	FANUC 0i-TF

PM-LH1300

Machining center machine

PM-LH1300

X axis 1300

Y axis 800

Z axis 700



The only way for competitive edge is to pursue efficiency and quality

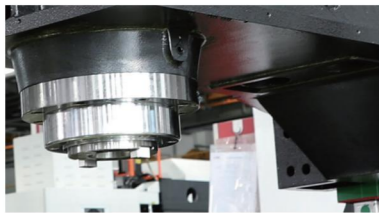

The spindle is standard with BT50
Belt type 8000rpm
The main shaft has no noise and small vibration
Suitable for high speed milling and tapping



Standard with 24 automatic knife change
Circle can be configured according to customer requirements
Disk automatic tool changing system, widely used.

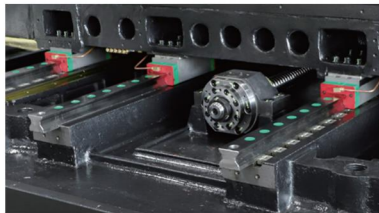

After finite element structure analysis,
A large number of reinforcement bars are used inside the casting
Make the internal mechanical structure of the machine more optimized,
Ensure the rigidity and thermal stability of the machine.

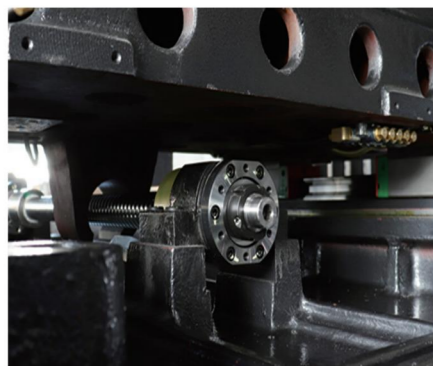

- High rigidity bed structure, finite element structure analysis with FEM, With a large number of reinforcing bars, the internal mechanical structure of the whole machine is more optimized to ensure the rigidity of the whole machine. Stability of sex and heat variation.
- Triaxial roller rail, small friction resistance, shorten the rapid displacement time, improve Production efficiency; At the same time through the excellent assembly process, can complete high precision products Processing.
- Adopt the large span base structure, with two 45mm roller rail, for the machine Provide very strong bearing capacity and meet the high rigidity requirements of heavy cutting.

MODEL		UNIT	PM-LH1100	PM-LH1300	PM-LH1500
Travel	X axis travel	mm	1100	1300	1500
	Y axis travel	mm	650	800	800
	Z axis travel	mm	650	700	700
	Distance from spindle center to column	mm	702	725	951
	Distance from spindle nose to table	mm	120~770	150 ~ 850	180~880
Table	Table area	mm	1200 × 600	1500 × 700	1700 × 800
	Max.load of table	kg	800	1000	1500
	T-slot	mm	18-5 × 125	18-5 × 150	22-5 × 150
Spindle	Spindle taper		BT40/150	BT50/155	BT50
	Spindle speed	rpm	10000	8000	6000
	Spindle drive		Belt type	Belt type	Belt type
	Spindle motor	kw	11/15	15/18.5	15/18.5
	Spindle cooling		lubricating grease	lubricating grease	lubricating grease
Feed Drive	3Axis motor output (X、 Y、 Z)	kw	3	4	4
	Rapid traverse (X、 Y axis)	m/min	36/18	24/18	24/18
	X axis rail specifications		Six sliders on two	Two rails with six sliders	
	Y axis rail specifications		Six sliders on two	Four track eight slide block	
	Z axis rail specifications			Hard rail	
	Minimum feed unit	mm	0.001	0.001	0.001
A.T.C	Magazine type		Knife arm type	Knife arm type	Knife arm type
	Tool magazine capacity	Pcs	24	24	24
	Full knife diameter	mm	Ø 80	Ø 110	Ø 110
	The diameter of the hollow blade	mm	Ø 150	Ø 200	Ø 200
	Longest tool	mm	250	300	300
Precision	Positioning	mm	0.007	0.007	0.007
	Repeatability	mm	0.006	0.006	0.006
Other	Power requirement	KVA	25	30	30
	Floor space(L × W × H)	mm	3100 × 2350 × 2800	3400 × 2930 × 2950	3900 × 3280 × 3150
	Air source requirements	kg	6.5	6.5	6.5
	Machine weight	kg	About 6950	About 9950	About 12300
	Controller		FANUC 0i-TF	FANUC 0i-TF	FANUC 0i-TF

DIMENSIONAL DRAWINGS

VMC-855 unit: mm

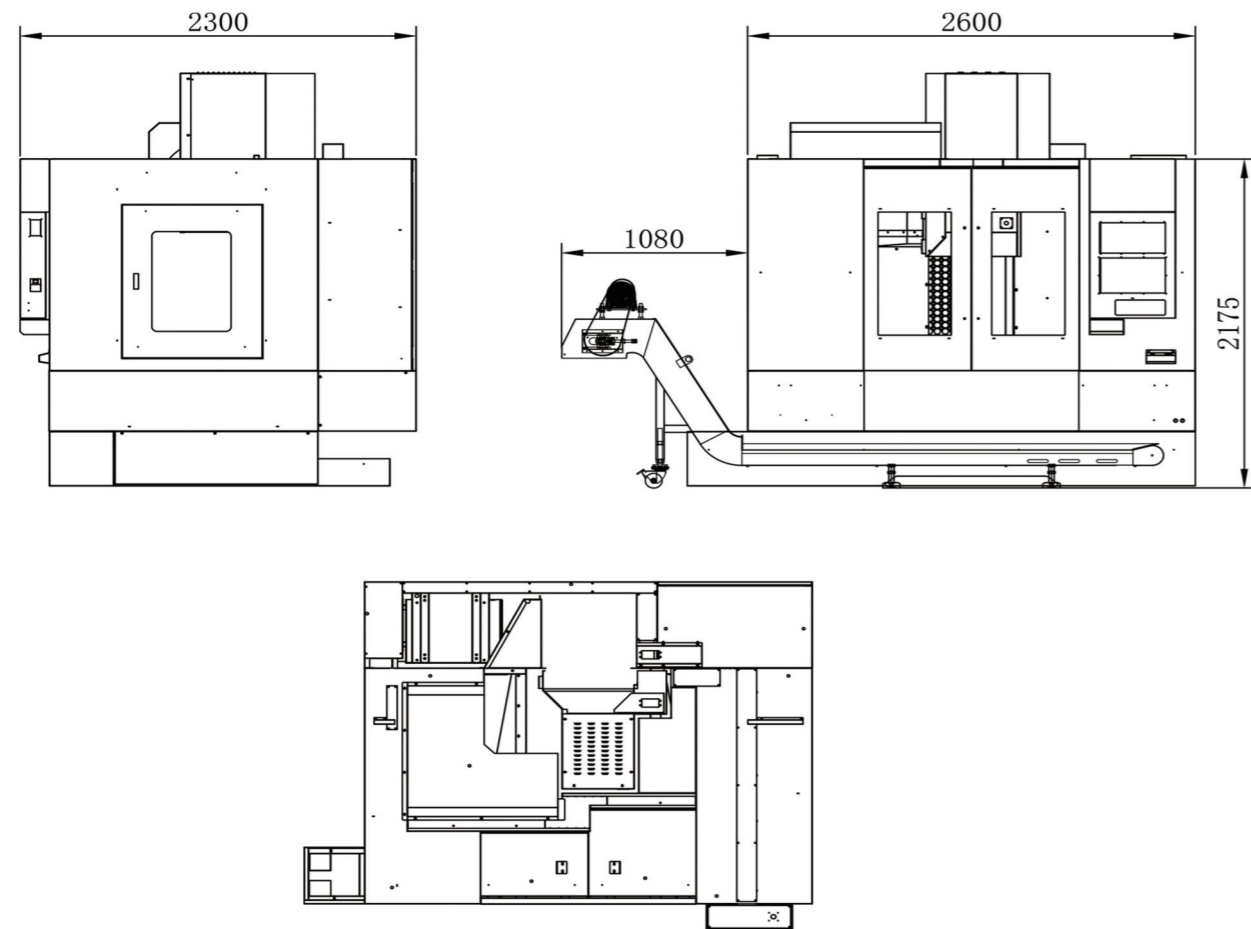

PM-L1100 unit: mm

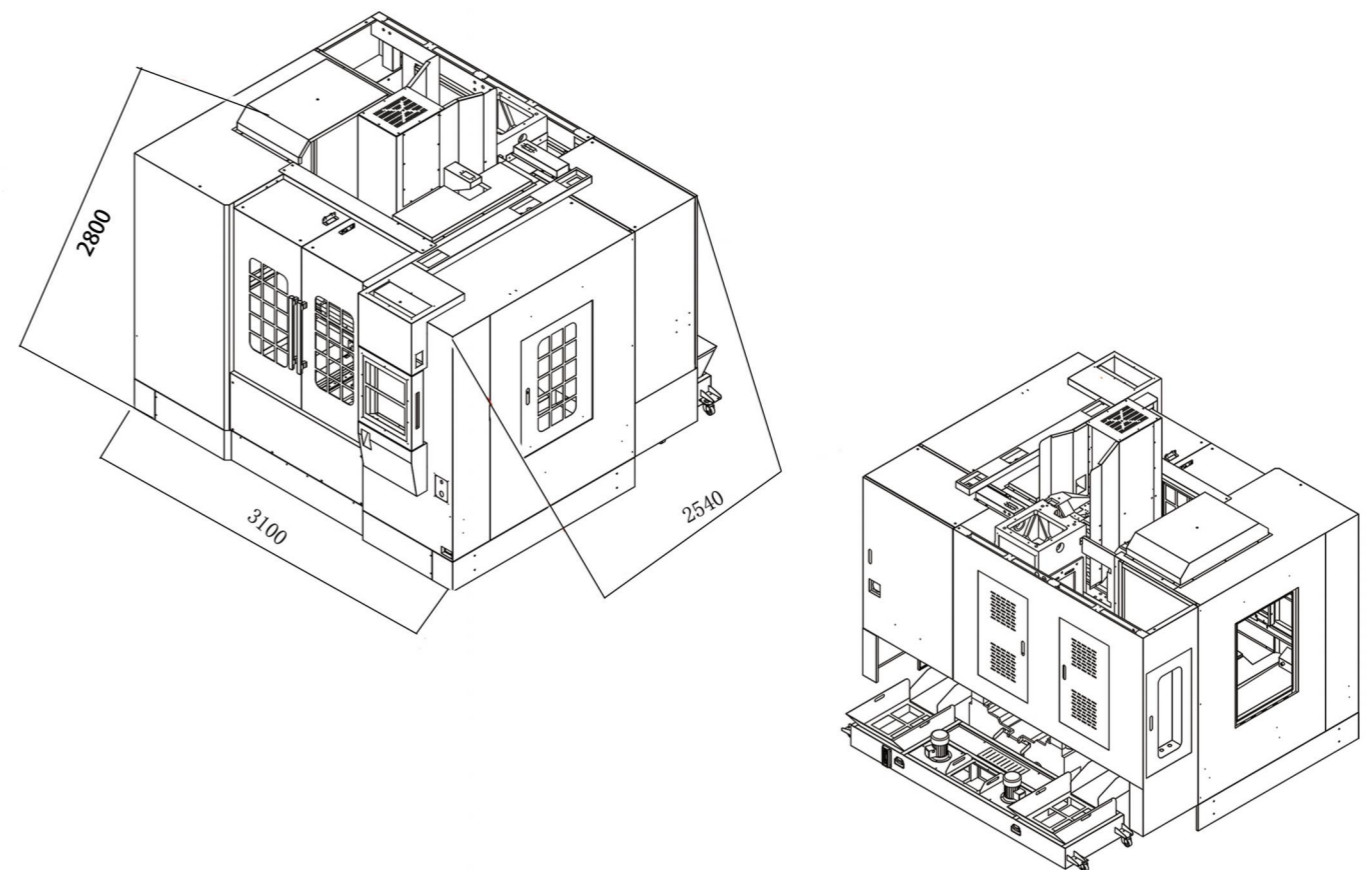

VMC-1100 unit: mm

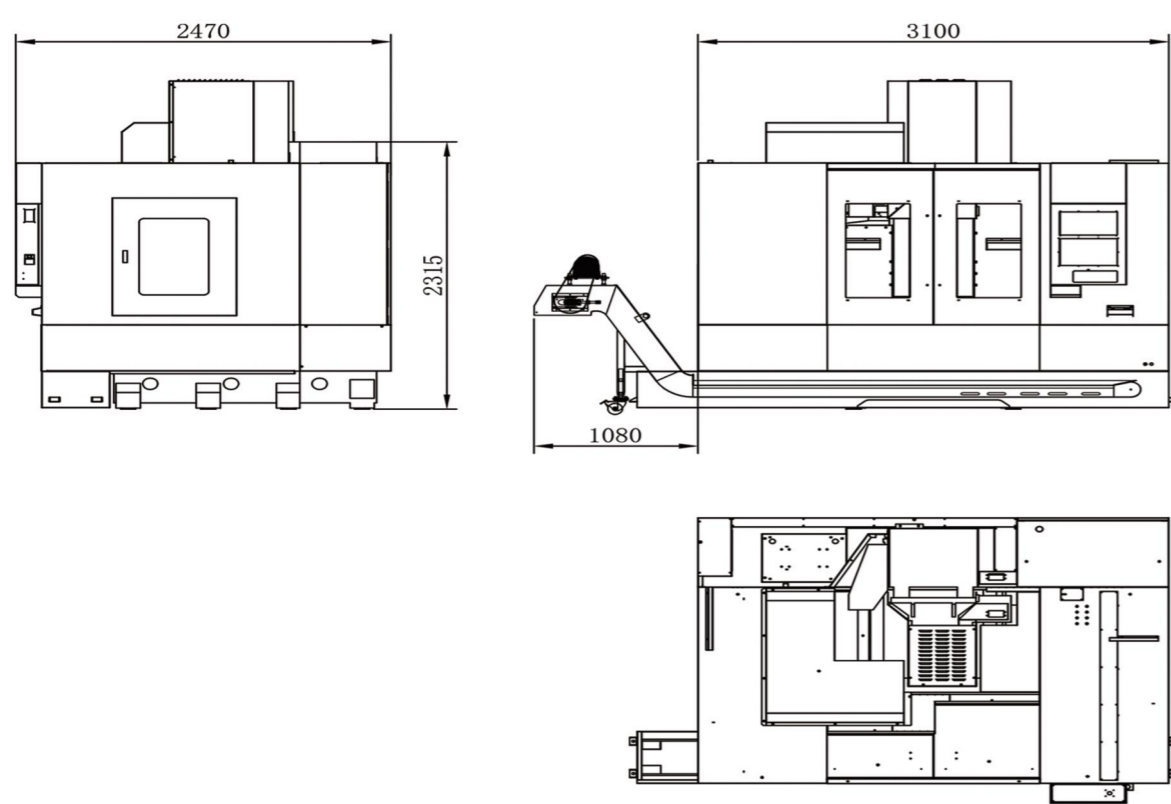

PM-L1200 unit: mm

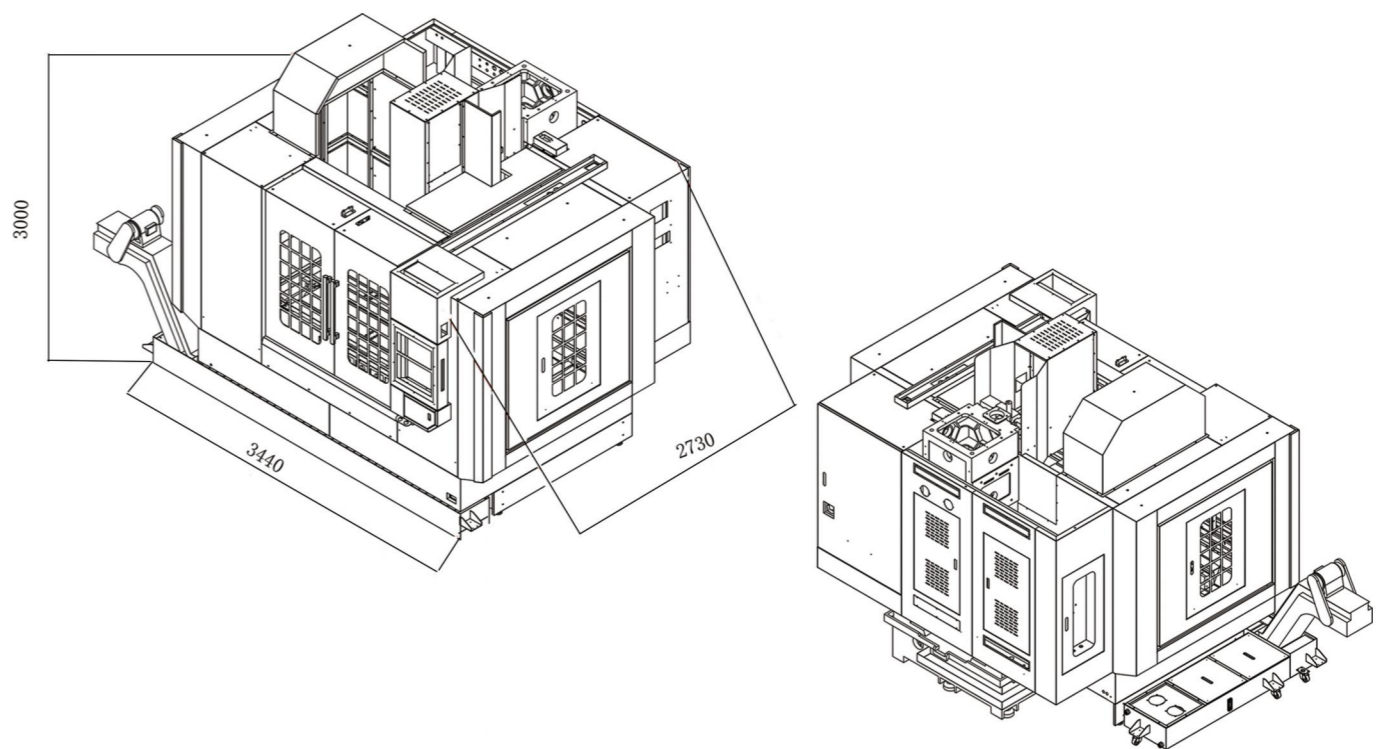

PM-L1500

unit: mm

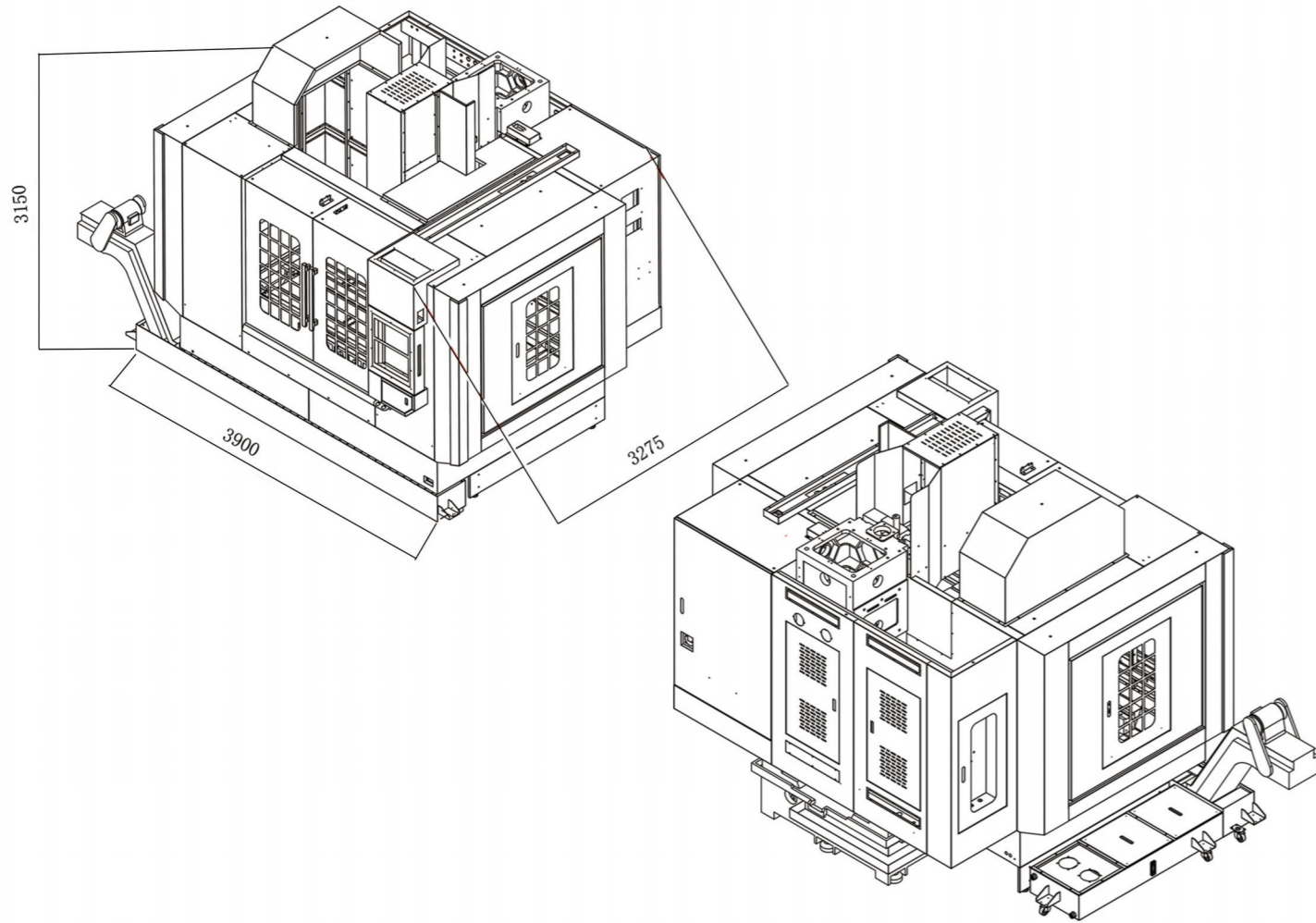

PM-LH1300

unit: mm



STANDARD /OPTIONAL SPECIFICATIONS

● Standard ○ Optional

No.	Description	VMC-855 VMC-1100	PM-L850	PM-L900	PM-L1100	PM-L1300	PM-L1500	PM-LH1300	PM-LH1500
1	Fanuc Oi-MF(3) Plus controller, 10.4" LCD, AICC II	●	●	●	●	○	○	○	○
2	Fanuc Oi-MF(1) Plus controller, 10.4" LCD, AICC II	--	--	--	--	●	●	●	●
3	Fanuc manual guide Oi function	○	○	○	○	○	○	○	○
4	Fanuc manual guide I function	●	●	●	●	●	●	●	●
5	Mitsubishi E80	○	--	--	--	--	--	--	--
6	Mitsubishi M80	○	○	○	○	○	○	○	○
7	Siemens controller	○	○	○	○	○	○	○	○
8	Heidenhain controller	○	○	○	○	○	○	○	○
9	Spindle speed 8,000 rpm belt driven	--	--	--	--	--	--	--	--
10	Spindle speed 10,000 rpm belt driven	●	●	●	●	●	●	●	●
11	Spindle speed 12,000 rpm direct driven	○	○	○	○	○	○	○	○
12	Spindle speed 15,000 rpm direct driven	○	○	○	○	○	○	○	○
13	Spindle taper BT40	●	●	●	●	●	●	●	●
14	Spindle taper BT50	--	--	--	--	○	○	○	○
15	Spindle taper BBT40 / DIN40 / HSK63A	○	○	○	○	○	○	○	○
16	Spindle taper BBT50 / DIN50 / HSK100A	--	--	○	○	○	○	○	○
17	Spindle motor 7.5/11 kw	○	○	--	--	--	--	--	--
18	Spindle motor 11/15 kw	●	●	●	●	--	--	--	--
19	Spindle motor 15/18.5 kw	--	--	○	--	●	●	●	●
20	2 step speed gear box	○	○	○	○	○	○	○	○
21	Spindle oil chiller	--	--	--	--	--	--	--	--
22	Tool magazine capacity - 24 tools	●	●	●	●	●	●	●	●
23	Tool magazine capacity - 30 tools	○	○	○	○	○	○	○	○
24	Ball type linear guide way	--	--	--	--	--	--	--	--
25	Roller type linear guide way	●	●	●	●	●	●	●	●
26	Box way	--	--	--	○	○	○	○	○
27	Coolant and chip flush system	●	●	●	●	●	●	●	●
28	Spindle taper cleaner	●	●	●	●	●	●	●	●
29	MPG	●	●	●	●	●	●	●	●
30	Heat exchanger for electrical cabinet	●	●	●	●	●	●	●	●
31	Air conditioner	○	○	○	○	○	○	○	○
32	Automatic lubrication system	●	●	●	●	●	●	●	●
33	Fully enclosed splash guard	●	●	●	●	●	●	●	●
34	Work lamp	●	●	●	●	●	●	●	●
35	End of program light (three colors)	●	●	●	●	●	●	●	●
36	Rigid tapping	●	●	●	●	●	●	●	●
37	M80 auto power off	●	●	●	●	●	●	●	●
38	Level bolts and pads	●	●	●	●	●	●	●	●
39	Screw type chip conveyor and chip cart	●	●	●	●	●	●	●	●
40	Chain type chip conveyor and chip cart	●	●	●	●	●	●	●	●
41	Coolant gun	○	○	○	○	○	○	○	○
42	Coolant through spindle	○	○	○	○	○	○	○	○
43	Oil skimmer	○	○	○	○	○	○	○	○
44	Oil mist collector	○	○	○	○	○	○	○	○
45	Automatic tool length measurement	○	○	○	○	○	○	○	○
46	Automatic workpiece measurement	○	○	○	○	○	○	○	○
47	Linear scale	○	○	○	○	○	○	○	○
48	CNC rotary index table	○	○	○	○	○	○	○	○
49	Auto door	○	○	○	○	○	○	○	○
50	Stabilizer	○	○	○	○	○	○	○	○
51	Transformer	○	○	○	○	○	○	○	○
52	CE approval	○	○	○	○	○	○	○	○

AR TECHNOLOGY

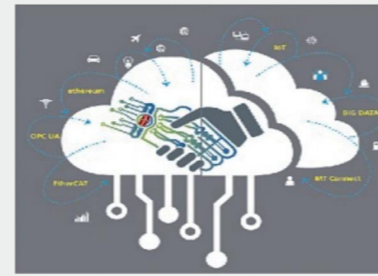
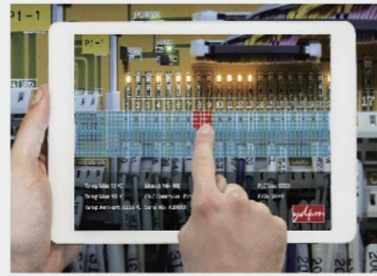

Since maintenance has a direct influence on performance, productivity and product quality, we're improving the process through recent developments in Augmented Reality technologies

Current efforts are focused on developing AR applications for maintenance.

SMART MACHINE ENGINE



Establish an Industry 4.0 administration console platform
 Communication platforms of various controller for machines, robots and automation equipment
 Master utilization of machine
 Remote program upload / download
 Alarm message analysis
 Machine's data analysis and statistics
 App of for developing smart machinery

PRODUCTION MANUFACTURER / PROCESS RECORDS

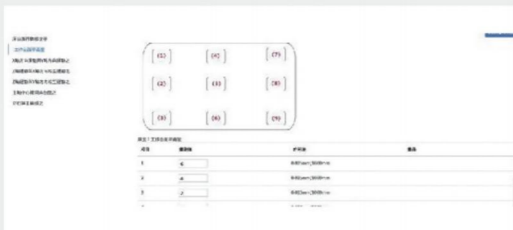

Upgrade to a smart production system for machine tools
 Management of assembly efficiency
 Visualization of assembly progress
 Analysis of machine assembly accuracy
 Estimated assembly time and controlled delivery time

FANUC AI THERMAL DISPLACEMENT COMPENSATION

After the thermal displacement compensation model file is imported into the system, the thermal displacement compensation is performed in real time according to feedback from each temperature sensor during the operation of the machine to improve the machining accuracy of the machine.

Model development tool

Temperature sensor

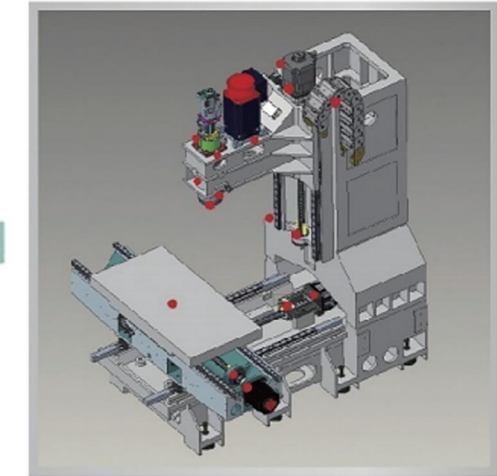

Compensation model

CNC

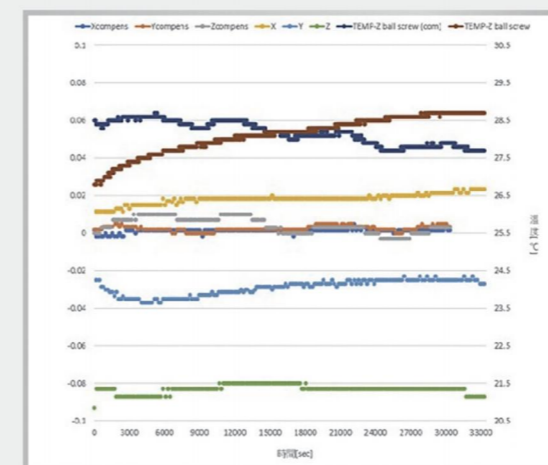

The FANUC AI Thermal Displacement Compensation module was implemented on PM-L850. The thermal displacement after applying AI adjustment is within 0.002 mm, compared to 0.08 mm without AI.